



MODEL E13SGH-E16SGB CENTER PIVOT

OPERATOR'S MANUAL – ORIGINAL INSTRUCTIONS

STUMP GRINDER INTENDED USE

The Barreto Stump Grinder is designed to remove in-ground tree stumps and exposed roots. It should not be used to cut any material other than wood stumps and the surface soil around the stumps or exposed roots. This machine is not a cultivator or a rotary hoe.

TABLE OF CONTENTS

LUBRICATION REQUIREMENTS	2
SAFETY MESSAGES	3
SAFETY INSTRUCTIONS OVERVIEW	4
STUMP GRINDER OPERATING INSTRUCTIONS	7
CONTROLS	7
ENGINE CONTROLS	9
ENGINE START UP PROCEDURE	9
OPERATOR PREPARATION	10
NOISE EMISSION DATA	10
VIBRATION EMISSION DATA	11
DETERMINE LOCATION OF UNDERGROUND UTILITIES	12
WORK SITE ASSESSMENT	13
CONTRACT WITH UNDERGROUND UTILITIES	14
GRINDING TIPS	15
GROUND TRANSPORT OF THE GRINDER	16
ROAD TRANSPORT OF THE GRINDER	17

LUBRICATION REQUIREMENTS

Grease at the intervals indicated per the illustration of grease lubrication points. There is also a grease diagram decal on the machine.

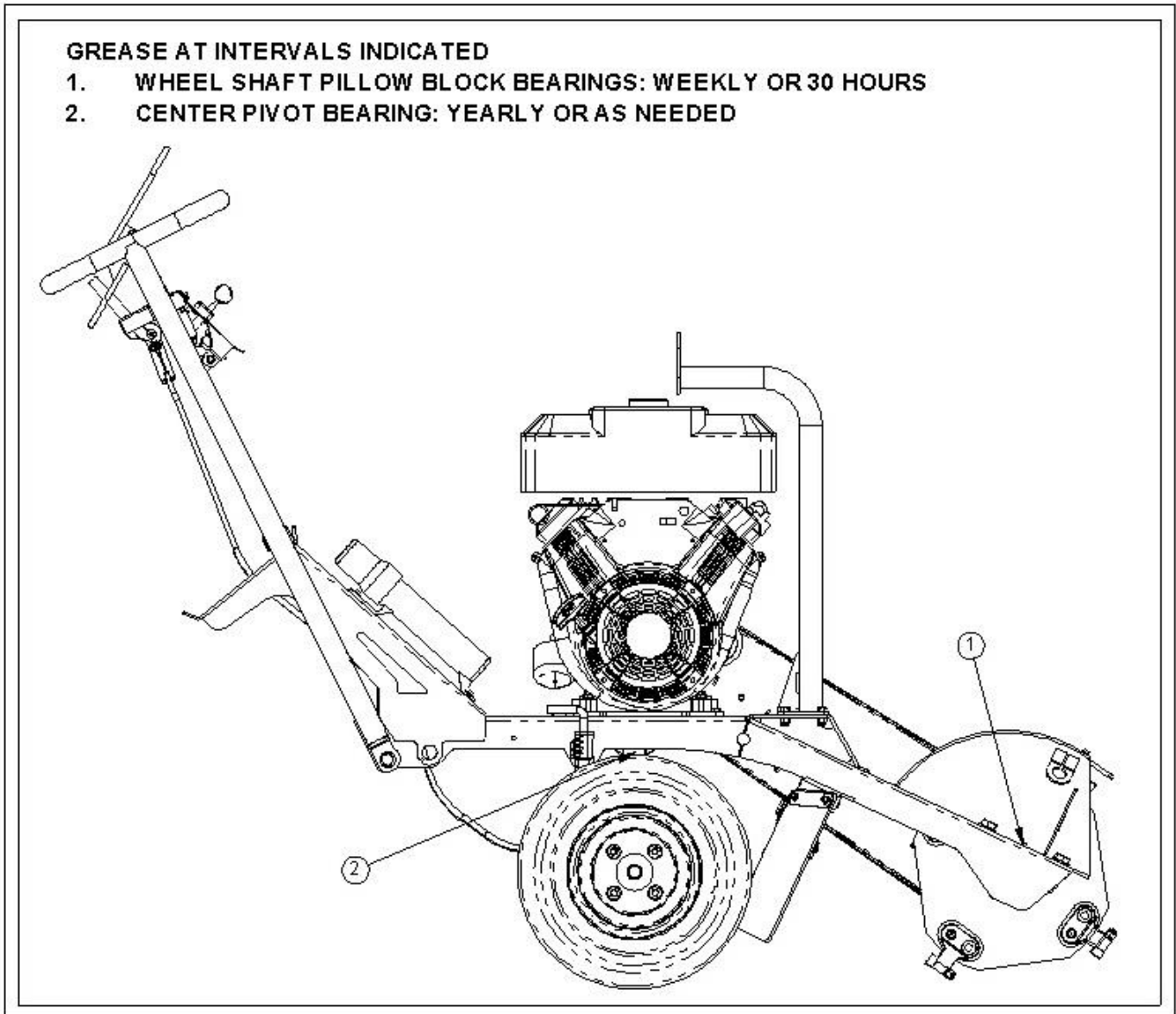

SAFETY MESSAGES

General safety messages are listed in this Safety Messages section. Specific safety messages appear as appropriate in this manual where a potential hazard may occur if procedures or instructions are not followed correctly and completely.

SAFETY SYMBOL



This is the international safety alert symbol. This symbol is used in combination with a signal word and written message to warn you of a potential for bodily injury or death.

A signal word "DANGER", "WARNING", or "CAUTION" is used with the safety alert symbol.



DANGER: Imminent hazards, that if not avoided, will result in serious personal injury or death.



WARNING: Potential hazards or unsafe practices, that if not avoided, could result in serious personal injury or death:



CAUTION: Potential hazards or unsafe practices, that if not avoided, could result in minor personal injury, product damage, or property damage.

Safety decals with a signal word "DANGER", "WARNING", or "CAUTION" are affixed to the stump grinder near specific hazards.

This machine shall always be used in accordance with this manual. Study it and ALL decals on the stump grinder before operating the stump grinder.

ALWAYS make sure the engine is turned off before performing maintenance, cleaning, or transport by means other than under its own power.

Before using, always visually inspect to see that the tools are not worn or damaged. Replace worn or damaged elements and bolts in sets to preserve balance.

Use extreme caution when reversing the machine towards you.

Do not change the engine governor settings or over speed the engine.

SAFETY INSTRUCTIONS OVERVIEW

READ SAFETY AND OPERATING INSTRUCTIONS BEFORE OPERATING!

USE COMMON SENSE AND PLENTY OF IT!

Call before you cut. If you do not call, you may cause an accident; suffer injuries or death; cause interruption of services; damage the environment; and/or incur project delays. Expect to be held liable for any damages caused, if you fail to call.

 **DANGER:** Buried electric cables or gas lines can cause serious injury or death if struck with cutter wheel. Always determine location of utilities before cutting.

 **WARNING:** Fiber optic cables convey laser light that can injure your eyesight.



STAY CLEAR of moving parts on the stump grinder.

 **DANGER:** Cutter wheel and other moving parts can cut off arms, legs, or fingers. Contact with the cutter wheel while in operation will cause serious injury or even death. Stay in the operator's position at the controls when the cutter wheel is operating. Keep all observers and helpers at a safe distance from the machine. Stop the cutter wheel immediately if anyone gets too close to the operating machine.

Wear a face safety shield and hardhat while operating or observing!

 **WARNING:** The cutter wheel may throw chips, rocks and debris into the area around the machine. Keep all bystanders at a safe distance from the machine. Always wear eye protection when operating or observing the machine in operation.

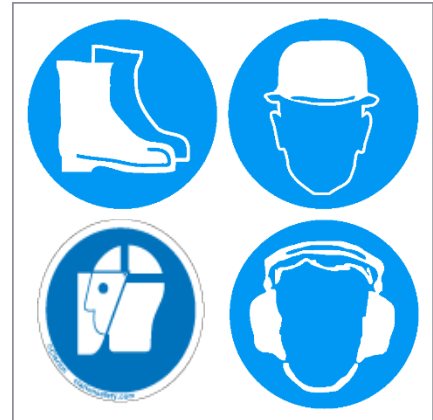

Wear adequate hearing protection while operating or observing.

 **WARNING:** The machine and cutter wheel are loud when in operation. Wear ear protection when operating the machine. Exposure to loud noise is cumulative and may permanently damage your hearing.

Wear safety boots and gloves. Wear close-fitting clothing. Contain long hair. Do not wear jewelry. Wear reflective clothing if working near traffic.

Only operate outdoors and avoid breathing engine exhaust and fumes.

 **WARNING:** Engine exhaust contains carbon monoxide gas that is toxic. Breathing it can cause unconsciousness and death.

Adequate lighting is required, daylight or artificial, for safe operation of the stump grinder. Allow adequate side and overhead clearances between machine and buildings, fences, and trees.

SAFETY INSTRUCTIONS OVERVIEW (continued)



WARNING: Contact with the cutter wheel while in operation will cause serious injury or even death. The teeth of the cutter wheel are sharp. Avoid contact even when the wheel is not moving.

Avoid inclines if possible.



WARNING: Navigating on any incline increases the danger of the machine losing traction or rolling over, especially if the surface is wet. If you lose control, get out of the way immediately to avoid personal injury. Navigation on inclines should be especially slow and turns very gradual. Refer to the incline diagram in the section, "GROUND TRANSPORT". Wheel housing frame must be locked before moving unit on any surface including inclines.

Avoid operating adjacent to drop-offs or embankments.

Always leave machine parked on a level surface.

Do not leave machine unattended with the engine running.

Do not operate machine near any source of flammable dust or vapors.



WARNING: Sparks from the engine exhaust can cause an explosion or fire in a flammable or explosive atmosphere. Fuel fumes can catch fire or explode.

Do not operate machine near flames or sparks.



WARNING: Fuel fumes can catch fire or explode. If fuel is spilled, do not attempt to start engine but move the machine away from the area of spillage and avoid creating any source of ignition until the vapors have dissipated.

Shut off engine and allow it to cool before refueling.



WARNING: Fuel fumes can catch fire or explode. Refuel outdoors and do not smoke when refueling. Do not refuel near a source flames or sparks. Always store fuel in containers specifically designed for this purpose. Add fuel before starting engine. Never remove the cap on the fuel tank or add fuel while the engine is running or when the engine is hot.



WARNING: Replace all fuel tank and container caps securely.

Do not touch the engine, muffler, or any of the belt components until cool.



WARNING: Muffler and engine get hot enough to cause serious burns. For the safety of yourself and others, allow enough time for the engine, muffler, and the hydraulic fluid to cool completely before performing any cleaning or maintenance.



WARNING: Stay clear of the articulation area while the engine is running.



WARNING: Never operate machine during storms or where lightning is present or nearby.

SAFETY INSTRUCTIONS OVERVIEW (continued)



WARNING: Keep safety guards and shields in place while the engine is running and keep all operator protection systems in place and in operational condition.



WARNING: Never store the equipment with petrol in the tank inside a building where fumes can reach an open flame or spark. Allow the engine to cool before storing in an enclosure. To reduce fire hazard, keep the engine, muffler, battery compartment and fuel storage area free of any vegetative material and excessive grease.

Keep others away. If the job site is near a road or pedestrian path, warn and divert both motorized traffic and pedestrians. As appropriate, use traffic flag personnel, signs, cones, and lighting devices to insure safety.

Never allow anybody to ride on the machine.

Never lift machine over any person at any time.



WARNING: If machine should fall, it would crush anybody under it.

We recommend having a fire extinguisher suitable for petrol fires in the operating area.

California Proposition

 **65 Warning** 

WARNING: This product contains chemicals known to the State of California to cause cancer, and birth defects or other reproductive harm.

ADVERTENCIA: Este producto contiene productos químicos reconocidos por el estado de California que provocan cancer, defectos de nacimiento u otros daños reproductivos.

For more information: www.P65Warnings.ca.gov

STUMP GRINDER OPERATING INSTRUCTIONS

READ SAFETY INSTRUCTIONS BEFORE OPERATING! Both the SAFETY INSTRUCTIONS and OPERATING INSTRUCTIONS are in this manual.

Be sure that the engine oil and fuel are all at proper levels before starting the engine.

STUDY AND UNDERSTAND CONTROLS BEFORE BEGINNING OPERATION.

CONTROLS

1. LOCATION: Move the Stump Grinder into position manually.
2. WHEEL LOCKS/PARKING BRAKE: When the Stump Grinder is in the correct position, lock the wheels in place by pulling the wheel lock/parking brake levers towards the operator.

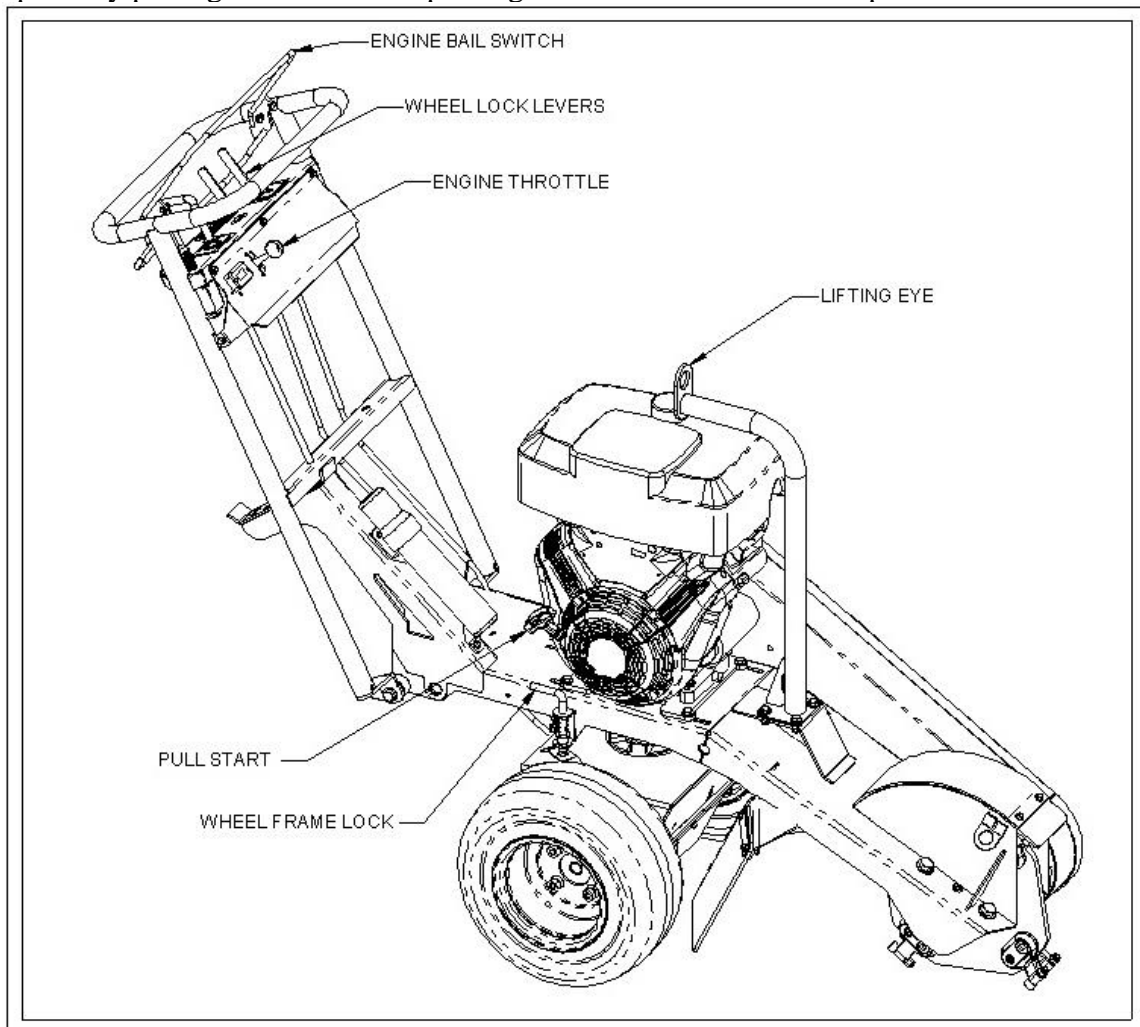

CONTROLS (continued)

4. **WHEEL FRAME LOCK:** when the Stump Grinder is in position and the wheels are locked, unlock the wheel frame lock by pulling up on the lock pin and rotating it to place the roll pin in the catch.

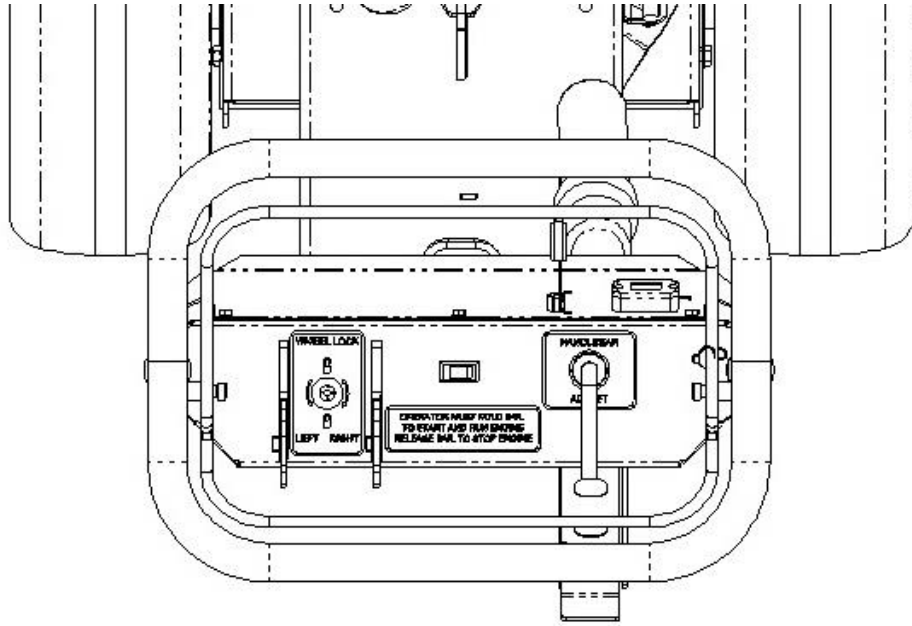

5. **ENGINE START:** Both Vanguard and Honda options are equipped with manual pull starts. The engine bail switch must be held down to allow the engine to start and run. If the bail is released, the engine will shut down. After the engine is running and warmed up, increase the engine speed fully to engage the centrifugal clutch and grinder wheel.

6. **GRINDING:** This Stump Grinder is manually pivoted back and forth to control the cutting and grinding. As the stump is ground down, the handlebars can be adjusted and lowered for optimal operator position.

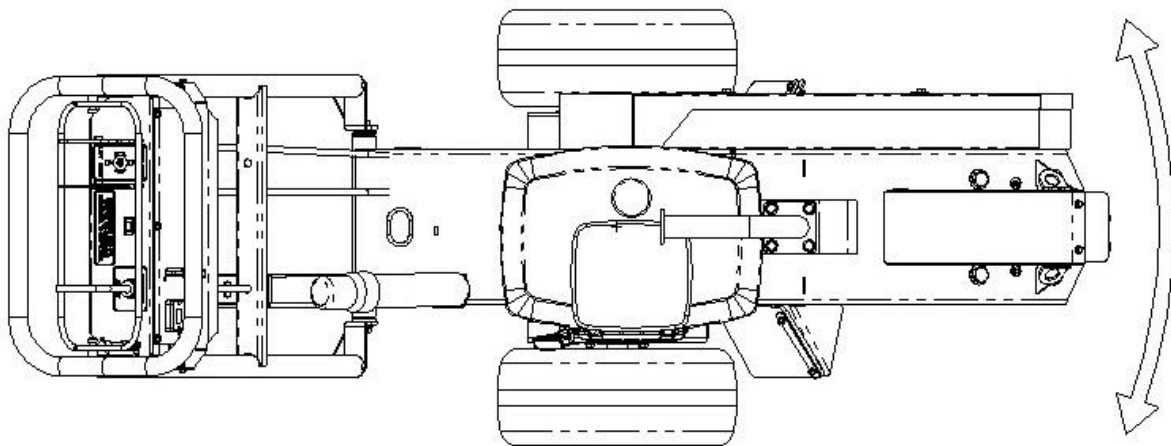

ENGINE CONTROLS

FUEL SHUTOFF VALVE: Must be in OPEN position for engine to run.

CHOKE: Use while starting the engine, only needed if engine has not reached operating temperature. (Refer to the ENGINE START UP PROCEDURE)

THROTTLE: Controls engine speed. Operate at full throttle when cutting (all the way forward).

ENGINE START UP PROCEDURE

Only operate machine outdoors and avoid breathing engine exhaust and fumes.



WARNING: Engine exhaust contains carbon monoxide gas that is toxic. Breathing it can cause unconsciousness and death. Avoid any areas or actions that expose you to carbon monoxide.

COLD WEATHER OPERATIONS: Before operating in cold weather, refer to the Engine Owner's Manual for recommended engine oil. Do not spray starting fluid into the air cleaner as engine damage could result.

Engine bail switch must be held down for engine to start and run. If the bail switch is released, the engine will shut down. Engine throttle must be set at idle before startup.

OPERATOR PREPARATION

Each operator must:

- Become familiar with the controls and operation of the stump grinder, preferably under the supervision of an experienced operator.
- Be at least 18 yrs. of age and be mentally and physically capable of operating the stump grinder safely.
- Have studied the SAFETY AND OPERATING INSTRUCTIONS in this manual.

PERSONAL PROTECTION: For safety, stump grinder operator should wear personal protection equipment. Keep observers at a safe distance and do not operate if people are near, especially children and pets.

Wear a face safety shield and hard hat while operating or observing!

 **WARNING:** The cutter wheel may throw wood chips, stones and debris.

Wear safety boots and gloves. Wear close-fitting clothing. Contain long hair. Do not wear jewelry. Wear reflective clothing if working near traffic.

Wearing adequate hearing (ear) protection while operating or observing is recommended.

 **WARNING:** Exposure to loud noise is cumulative

Hearing protection is mandatory. Hearing devices do not all provide the same level of protection. Those that completely surround each ear are better than earplugs. It is important to select a device that is adequate and appropriate for your specific work environment since the peak noise level varies. A local environmental noise specialist may help you to determine the level of hearing protection required.



NOISE EMISSION DATA

Machinery Directive declaration

DECLARED DUAL-NUMBER NOISE EMISSION VALUES in accordance with ISO 4871	
	Normal Operation
Measured A-weighted sound power level, L_{WA} (ref. 1pW) in decibels	107
Uncertainty, K_{WA} , in decibels	2
Measured A-weighted sound pressure level, L_{pA} (ref. 20 μ Pa) at the operator's position in decibels	92
Uncertainty, K_{pA} , in decibels	4
Values determined according to noise test code given in EN 709:1997+A4:2009 and ISO 3744:1994, and are rounded to the nearest decibel according to ISO 4871.	
NOTE 1 - The sum of a measured noise emission value and its associated uncertainty represents an upper boundary of the range of values, which is likely to occur in measurements.	

Values listed above are rounded to the nearest decibel according to ISO 4871

Noise Emissions Directive result.

Guaranteed sound power level	109 dB
-------------------------------------	---------------

NOTE - The guaranteed sound power level is calculated from unrounded values, and may differ from the values above

VIBRATION EMISSION DATA

Declared vibration emission value in accordance with EN 12096: the average measured vibration emission value is 2.0 m/s². The uncertainty in the measurement is 2.4 m/s². Safety gloves help to isolate the hands from the vibration, keep them warm and dry, maintain blood circulation, and make operators less susceptible to vibration induced injury.

The Barreto Stump Grinder, Model E16SG when operated in accordance with its instructions, and tested in accordance with EN 1033:1995, results in the following vibration emission declared in accordance with EN 12096:1996.

Average measured vibration emission value	a_{hv}	2.278	m/s²
Uncertainty	K	0.034	m/s²

These values are suitable for comparison with the vibration emission levels of other tools that have been obtained using the same test method.

Note: these figures represent the average value over 5 tests, with the figures in the x, y, and z axes

combined in a vector sum ($a_{hv} = \sqrt{a_{hwx}^2 + a_{hwy}^2 + a_{hwz}^2}$). It is this sum that is averaged over all tests.

Since the value stated above is an average of several tests, and is based on data from all three axes, we consider it to be a reasonable approximation of the true value, particularly considering the uncertainty in the results (K).

This machine is unlikely to cause hand-arm vibration syndrome, as the average emission level is equal to or less than 2.5 m/s²

DETERMINE LOCATION OF UNDERGROUND UTILITIES

OSHA CFR 29 1926.651 requires that the estimated location of underground utilities be determined before beginning excavation or an underground drilling operation. When the actual excavation or bore approaches an estimated utility location, the exact location of the underground installation must be determined by a safe, acceptable and dependable method. If any utility cannot be precisely located, the appropriate utility company must shut it off.

Call before you cut. If you do not call, you may cause an accident; suffer injuries or death; cause interruption of services; damage the environment; and/or incur project delays. Expect to be held liable for any damages caused, if you fail to call.



DANGER: Buried electric cables or gas lines can cause serious injury or death if struck with cutter wheel. Always determine location of utilities before operating the machine.



WARNING: Fiber optic cables convey laser light that can injure your eyesight.

Before digging, contact the appropriate utility companies to locate and mark the underground installations. Do not rely on visual evidence of underground utilities such as manhole covers or electrical drop boxes...**CALL!**

WORK SITE ASSESSMENT

Examine the work area for any conditions or obstructions that may inhibit cutting or create a safety hazard for the operator or others. Use the information in this manual combined with good judgment to identify any hazards to avoid.

In addition to calling to DETERMINE LOCATION OF UNDERGROUND UTILITIES (see previous section for details) the operator and/or job foreman should visually inspect the work site. Look for electrical drop boxes; notices of underground placements; manhole covers; recent cutting activity; any evidence of possible underground placements; banks; overhangs; drop-offs; rocks; tree limbs; wire; uneven terrain; any existing trenches or holes; and toxic ground conditions.

Only operate stump grinder outdoors and avoid breathing engine exhaust and fumes.



WARNING: Engine exhaust contains carbon monoxide gas that is toxic. Breathing it can cause unconsciousness and death.

Do not operate stump grinder near any source of flammable dust or vapors.



WARNING: Sparks from the engine exhaust can cause an explosion or fire in a flammable or explosive atmosphere. Fuel fumes can catch fire or explode.

Allow adequate side and overhead clearances between stump grinder and any objects such as buildings, fences, and trees.

Adequate lighting is required, daylight or artificial, for safe operation of the stump grinder.

Keep others away. If the job site is near a road or pedestrian path, warn and divert both motorized traffic and pedestrians. As appropriate, erect barriers, use traffic flag personnel, signs, cones, and lighting devices to insure safety.

CONTACT WITH UNDERGROUND UTILITIES

After LOCATING UNDERGROUND UTILITIES and performing the WORK SITE ASSESSMENT, accidental contact with a buried utility might still occur. If it does, stop and call emergency services for help.

If you cut a wire or cable, assume that you do not know what kind it is. It may be electrical or any one of several communication lines: telephone, television, or fiber optic. In any case, do not touch it or even look at the ends of it. Stop cutting and call emergency services for help. Do not cut any more until the appropriate utility company has assessed the situation, taken appropriate action, and informed you that is safe to proceed.

If you strike a pipe, it could be gas, oil, petroleum, water, or sewer. In any case, stop cutting, shut off the engine, and evacuate the area immediately. Call emergency services for help.

Electrical wires or cables: If you think that you may have severed electrical wires, stop cutting and call emergency services for help. Keep yourself and other people away from the area.



DANGER: An electric shock could kill you. Assume that any severed wire or cable is HOT with voltage and do not touch it!

Gas lines: If you think that you may have struck a gas line, shut off the engine and evacuate the area immediately. Call emergency services for help.



DANGER: A gas explosion could kill you. Sparks will likely occur from the cutter head scraping the metal pipe. If gas leaks out an explosion could easily occur.

Fiber optic cables: If you think that you may have severed a fiber optic cable, do not touch or even look at the ends of it.



WARNING: Fiber optic cables convey laser light that can injure your eyesight. Call emergency services for help.

GRINDING TIPS

Clear the work area of debris, branches and rocks.

Operate the cutter with engine at full throttle.

Listen to engine speed and watch cutter wheel speed. Adjust swing speed and cut depth to maintain high engine and cutter speed. Avoid bogging the engine and stalling cutter wheel.

It is more efficient to cut the edge of the stump, rather than cutting a wide area. Once the teeth are cutting at a depth below half the wheel radius, lift the cutter and move the machine forward to begin cutting a new edge.

SHUT DOWN PROCEDURE

1. Always leave machine parked on a level surface.



WARNING: Do not park on incline. Move the machine to a level surface and set the wheel locks.

2. Reduce the ENGINE THROTTLE to idle until cutter wheel stops spinning.

3. Move the IGNITION SWITCH to the OFF position to stop the engine.

4. Lock wheel housing frame before moving machine

Shut off engine and allow it to cool before refueling.



WARNING: Fuel fumes can catch fire or explode. Do not smoke or allow flames or sparks in the area.

Do not touch the engine, muffler, or any of the belt components until cool.



WARNING: Muffler and engine get hot enough to cause serious burns.

For the safety of yourself and others, allow enough time for the engine, muffler, and the hydraulic fluid to cool completely before performing any cleaning or maintenance.



GROUND TRANSPORT OF THE STUMP GRINDER



WARNING: Contact with the cutter wheel while in operation will cause serious injury or even death. The teeth of the cutter are sharp. Avoid contact even when the cutter is not moving.

Never make sudden changes in speed or direction.

Use extra caution on soft or uneven ground.

Avoid operating adjacent to drop-offs or embankments.

Avoid inclines if at all possible. Never use on any incline exceeding the angles shown below.

Always have wheel housing frame locked before moving machine.



WARNING: Navigating on any incline increases the danger of the machine losing traction or rolling over, especially if the surface is wet. If you lose control get out of the way immediately to avoid personal injury. Navigation on inclines should be especially slow and turns very gradual.

A 20° maximum incline is allowed.

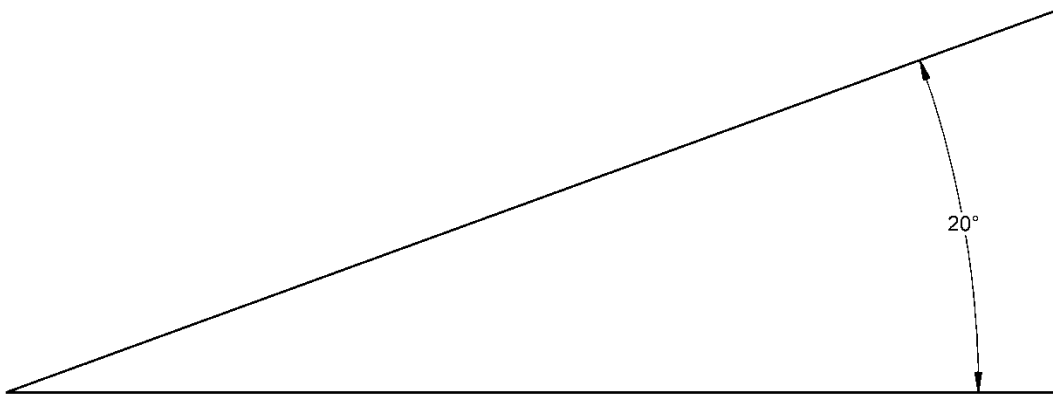

ROAD TRANSPORT OF THE STUMP GRINDER

The **BEST** way to transport the stump grinder over roads is with the **BARRETO E3X4 OR E4X6 TILT BED TRAILER**.

Refer to the following checklist before towing:

- Towing vehicle should have a 2" (5cm) ball. Be sure it is in good repair and securely fastened to the vehicle.
- Securely fasten the hitch to the ball by tightening the hitch nut.
- Cross the chains under the trailer tongue to prevent the tongue from dropping to the ground if the trailer comes loose.
- Allow only enough slack in the chains to permit proper turning of the vehicle. Do not let the chains drag on the ground or be drawn up too tight. Slack strength should hold the tongue and coupler off the ground with the trailer loose.
- Attach the safety chain to the towing vehicle in such a way that it cannot come off accidentally.
- Check the hitch-to-ball connection after driving a few blocks and re-tighten if necessary.

Always exercise extreme caution and allow extra clearance while towing a trailer. **DRIVE SAFELY!**

LOADING PROCEDURE of the stump grinder onto the **Barreto E4X6 tilt bed trailer**:

1. Position the tow vehicle and attached trailer on level ground.
2. Unlatch the trailer tilt bed latch pin to tip up the trailer bed. Leave the latch pin where the spring-loaded action will engage the pin with the latch when the bed is leveled again.
3. Line up the stump grinder with the rear of the trailer. The cut head should be toward the trailer.
4. Push the stump grinder slowly forward onto the trailer bed. As the weight of the stump grinder reaches the balance point the bed will level itself.

 **WARNING:** Navigating on the inclined trailer bed increases the danger of the tracks losing traction, especially if the bed surface is wet. Stay out of the way to avoid personal injury if you lose control.

Check that the trailer tilt bed latch pin is engaged with the latch. Use the tie down points shown below to strap unit to trailer or truck bed.

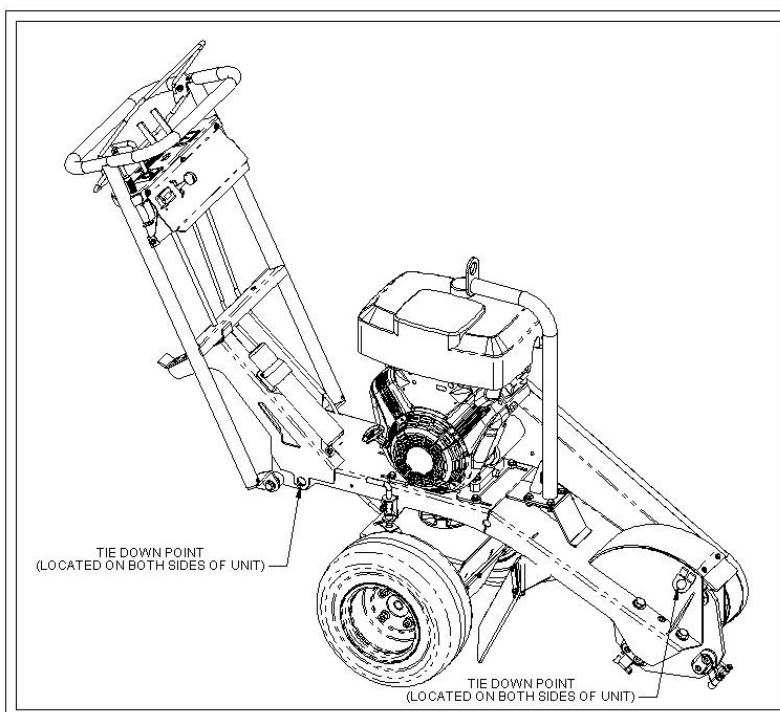

ROAD TRANSPORT OF THE STUMP GRINDER (continued)

UNLOADING PROCEDURE of the stump grinder from the **Barreto E4X6 tilt bed trailer**:

1. Position the tow vehicle and attached trailer on level ground.
2. Remove all chains or straps connecting the stump grinder to the trailer D-rings
3. Unlatch the trailer tilt bed latch pin and rotate the latch pin handle to lock it open.
4. Drive the stump grinder slowly backward. As the weight of the stump grinder reaches the balance point the trailer bed will tilt up. Continue backward until the unit is completely on the ground

TRUCK BED TRANSPORTATION OF THE STUMP GRINDER

LOADING PROCEDURE of the stump grinder onto a truck bed using a hoist:

Never attempt to hoist the stump grinder unless suitable equipment is available to lift and lower machine onto the truck. If using a sling, the minimum required working load limit per sling leg is 1000 lb (450 kg). Minimum sling leg length is 6 ft (2 m).

1. Position the truck and stump grinder on level ground.
2. Follow the stump grinder SHUT DOWN PROCEDURE.
3. Attach lifting sling or hook to the eye of the lift tube above the engine



Never lift stump grinder over any person at any time.

 **WARNING:** If stump grinder should fall it would crush anybody under it.

4. Chain or strap the stump grinder to the truck using the two chain loops at the rear of the stump grinder lower body and D-ring on front of the stump grinder.