

THE
BARRETO

MODEL 13STKH & 16STKB

SMALL TRACK TRENCHER OWNER'S MANUAL

CONGRATULATIONS!

You are now the proud owner of the BARRETO Small Track Trencher (STK). The OPERATOR'S MANUAL is attached to the machine. Read this manual and the operator's manual to become familiar with the STK, its characteristics, and method of operation. Pay attention to the safety and operating instructions to prevent personal injury or equipment damage.

If you have any questions or need any replacement parts, contact us at your convenience. Our toll-free phone number, fax and email are listed below.

THANK YOU for your patronage and confidence in BARRETO equipment.

Barreto Manufacturing, Inc.
Innovative Equipment Engineered to Last
66498 Hwy 203, La Grande, OR 97850
(800) 525-7348 (541) 963-7348
FAX (541) 963-6755
E-Mail: info@barretomfg.com
Web Site: <http://www.barretomfg.com>
US Patent# 9,988,084

Machine Identification Record

Machine model number _____

Machine serial number _____

Engine manufacturer _____

Engine model number _____

Engine serial number _____

TABLE OF CONTENTS

TABLE OF CONTENTS	2
WARRANTY OF BARRETO MANUFACTURING EQUIPMENT	2
INITIAL INSPECTION INSTRUCTIONS	3
SAFETY MESSAGES	3
ASSEMBLY INSTRUCTIONS	4
INTENDED USE	4
OPERATOR TRAINING.....	5
MAINTENANCE PREPARATION	6
ROUTINE MAINTENANCE	7
HYDRAULIC SYSTEM.....	8
HOUR METER	8
ENGINE MAINTENANCE.....	9
LUBRICATION REQUIREMENTS	9
DIG CHAIN INSTALLATION / REPLACEMENT	10
TRACK MAINTENANCE	11
BATTERY SAFETY INSTRUCTIONS.....	13
BATTERY MAINTENANCE	14
STK TROUBLE SHOOTING GUIDE	16
SPECIFICATIONS	18
INDEX.....	18

WARRANTY OF BARRETO MANUFACTURING EQUIPMENT

Barreto Manufacturing, Inc. warrants all BARRETO equipment to be free of defects in material and workmanship for a period of one (1) year. All BARRETO fuel components, fuel tank, cap, lines & fittings are warranted for two (2) years. Warranty period begins on date of delivery to the original user. This warranty is in lieu of all other warranties, whether written or implied, and is limited to:

1. Replacement of parts returned to the dealer and/or factory and determined defective upon inspection. (Replacement for parts to dealers shall be at dealer cost plus shipping charges.)
2. Time for pick-up and/or delivery, transportation of service calls by dealers is excluded. Manufacturer reserves the right to determine reasonable time required for repair.

Warranty does not apply to damage caused by abuse or neglect. Time and materials required for normal maintenance and service are also excluded from warranty coverage.

Engines, engine attached fuel tanks, engine accessories, batteries and tires are warranted by the original manufacturer and are not covered by the Barreto Equipment Warranty.

Wear parts such as dig chains, dig teeth, sprockets, chain rollers, bearings, bushings etc. are excluded unless it can be determined that a defect has contributed to premature wear.

INITIAL INSPECTION INSTRUCTIONS

Upon delivery, check for freight damage and missing items. All hardware necessary for complete assembly is included. There is a pre-shipping inspection sheet and /or a packing slip included, review these to make sure that all components have arrived.

- **If there are damaged or missing components:** document the damage on the delivery receipt, notify the carrier and Barreto Manufacturing immediately.

SAFETY MESSAGES

This section covers the method used to announce safety messages. Safety messages appear as appropriate in this manual and on decals affixed to the machine where a hazard may occur if procedure or instructions are not followed correctly and completely.



This is the ISO general warning symbol
Standard No.: 7010:2011

It is used in conjunction with the following signal words to communicate a hazard.

Safety signal words **DANGER WARNING CAUTION**, definitions from: ISO 3864-2.2016

- **DANGER:** Indicates an imminently hazardous situation which, if not avoided, will result in death or serious injury.
- **WARNING:** Indicates a potentially hazardous situation which, if not avoided, could result in death or serious injury.
- **CAUTION:** Indicates a potentially hazardous situation which, if not avoided, could result in minor or moderate injury.
- **NOTICE:** (Not safety related) Damage to property may occur. The situation is not considered hazardous, injury is unlikely. The general warning symbol will not be used.

Study ALL decals on the STK before operating the STK.

ALWAYS USE COMMON SENSE AND THINK SAFETY FIRST!

Emergency & Medical Contacts:

USA & CANADA: Emergency dial **911**

USA & CANADA: American Association of Poison Control Centers: **1-800-222-1222**

Outside the USA & Canada (fill in the appropriate number)

National Emergency number: _____

Poison Control Center: _____

Other: _____

ASSEMBLY INSTRUCTIONS

 **DANGER:** Before beginning assembly, engine start-up must be prevented. See MAINTENANCE PREPARATION section page 6.

 **WARNING:** The STK and components are heavy. Only lift the STK by mechanical means. Always team lift heavy components: “Lifting loads heavier than about 50 pounds will increase the risk of injury.” (OSHA)

All positional directions are from the reference of the operator while standing at the STK controls.

Before assembly:

- Read the section MAINTENANCE PREPARATION on page 6.
- Check hydraulic fluid level using sight glass on tank. See HYDRAULIC SYSTEM in this manual.
- Check engine oil before starting the engine. See engine owner’s manual.
- Refer to drawings 00579 and 00580 in your assembly exploded views manual.

Assembly:

- Remove the parts box, boom, boom guard and chain from the shipping crate.
 - Zip ties are used to hold the boom cushion in place.
 - The pin and cotter pin are in the chain, the pin is directional, note the direction of the pin.
 - The chain guard, deflector brace & fasteners (bolts, nuts, spacers, washers) are in the parts box.
- Remove the banding, sides and top of the crate to gain access to the STK.
- Place the boom on the extension of the motor housing then cut and remove the zip ties. Slide the boom on as far as it will go, the chain tension adjustment screw (square head) must be backed off.
- Install the dig chain: See section DIG CHAIN MAINTENANCE AND REPLACEMENT
- Place the boom guard mount inside the side walls of the chain motor housing, install with provided fasteners.
- Install the chain guard and deflector brace with provided fasteners.
- Grease all of the grease points; see GREASE CHART on page 9.
- Double check all steps of this process.
- Add gasoline to the gas tank.
- The STK is ready to trench.

INTENDED USE

The STK is designed for digging trenches in “normal” ground of reasonably soft dirt and stones up to 6” (15cm) in diameter. Ground with larger stones, high clay content, very hard packed, very dry or frozen may be unsuitable for normal trenching. Consider using a backhoe or other heavier equipment for such conditions.

OPERATOR TRAINING

Do not permit anyone to operate the STK without proper instruction and training.

Do not permit anyone to operate the STK if you believe that they cannot safely operate the STK.

Everyone who operates (or assists) an STK must know the following aspects of machine operation BEFORE operating the STK. Each aspect must be a part of operator training. Each operator must be at least 21 years old, mentally and physically able to safely operate the STK.

Rental companies need to explain and demonstrate all machine operations to each rental customer.

- **KNOW AND UNDERSTAND ALL SAFETY POINTS AND CONSIDERATIONS.**
- Check that all guards/covers and safety decals are in place.
- Understand the STK capabilities and intended use.
- Know all safety points.
- Know how to properly load and secure the STK to a trailer or truck bed.
- Know how to properly connect and secure the trailer to a towing vehicle.
- Know and understand all STK controls including:
 - Operator working area & areas to stay clear
 - Operator controls – Control panel layout
 - Engine controls: start, stop & throttle
 - Track drive controls
 - Adjustable trenching controls
 - Raise and lower the digging boom
 - Dig chain controls
- Know how to start a trench.
- Understand lubrication requirements.

Have the customer operate the STK and engage each control to gain familiarity with the machine while still at the rental yard.

The operator's manual is written as a guide for operator training and instruction. It covers each of the above points of machine operation.

MAINTENANCE PREPARATION

 **DANGER:** BEFORE beginning any maintenance on the STK that requires a guard be removed or exposes a part that moves during operation, prevent engine start-up.

 **WARNING:** The engine, exhaust pipe, engine oil and hydraulic system get hot during operation. Allow adequate time to cool before beginning maintenance.

Only trained and qualified personnel should perform maintenance or repairs of the STK or the battery.

Before any maintenance is performed engine start-up must be prevented, to eliminate the risk of someone starting the engine while the maintenance technician is still working.

Prevent engine start-up:

- **TURN ALL ENGINES SWITCHES OFF:** Turn / flip the engine kill switch, located on the engine to OFF. Turn the key to the off position and remove the key, store where no one can attempt to start the STK.
- **DISCONNECT THE BATTERY: See: BATTERY SAFETY INSTRUCTIONS first.** Disconnect the negative battery cable at the STK chassis. Use zip ties to hold the cable such that the cable terminal does not contact any part of the STK.
- **ZIP TIE THE PULL STARTER:** Use a zip tie to tie the pull start handle so that no one can attempt to start the engine.

 **WARNING:** The battery contains sulfuric acid that can cause blindness and severe burns. Avoid contact with eyes, skin and clothing. Read the section: BATTERY SAFETY INSTRUCTIONS, in this manual.

 **DANGER:** Hydraulic oil is hot and under extreme pressure, which will burn and cut. **DO NOT** operate machine if it is believed or known to be leaking.

DO NOT check for hydraulic oil leaks while engine is running.

DO NOT check for hydraulic oil leaks with your hand or any other body part.

If cut or injected with hydraulic oil seek medical attention immediately, even if injury appears to be minor. If hydraulic oil does not break skin, contact is not expected to cause prolonged or significant irritation.

California Proposition

 **65 Warning** 

WARNING: This product contains chemicals known to the State of California to cause cancer, and birth defects or other reproductive harm.

ADVERTENCIA: Este producto contiene productos químicos reconocidos por el estado de California que provocan cancer, defectos de nacimiento u otros daños reproductivos.

For more information: www.P65Warnings.ca.gov

ROUTINE MAINTENANCE

Routinely check the condition and clean, tighten, repair, or replace as necessary the following:

- Safety decals
- Muffler guard
- Fuel tank & hoses
- Fasteners
- Hydraulic hoses & fittings
- Dig chain & Auger
- Chain roller
- Engine oil
- Grease points

Replacement parts:

Replacement trencher parts and decals can be purchased from Barreto Manufacturing.

Replacement engine parts must be purchased from the engine manufacturer or dealer.

Decals:

Clean decals as necessary using soap and water. Replace damaged or missing decals. Remove damaged decals using a heat gun. When ordering a part that has decals affixed to it, order the decals also. When affixing decals, the mounting surface must be clean and above 40°F (5°C). To ease decal placement, fill a spray bottle with water and add one drop of dish soap, lightly coat the mounting surface with a mist of the soap-water, too much soap will ruin the decal adhesive. Place the decal on the surface and use a decal squeegee to wipe out all soap-water and air bubbles. Alternatively, the mounting surface can be dry.

NOTICE:

- Keep dig chain and undercarriage clean to prevent rust, excess wear, and maintain performance.
- **DO NOT** pressure wash or hose down bearings. Water will enter the bearing and dramatically reduce bearing life. Wipe away grease, dirt and grime that accumulate on or near a bearing.
- Solvents and abrasive cleaners will damage decals.
- Service the engine according to the engine owner's manual. Follow all directions for service and safety.
- Ethanol gasoline blends, common in the U.S., have a shelf life of about 90 days. Using expired fuel will result in poor engine performance and introduce contaminants such as water into the engine.
- Engine – pump couplers must have a 1/16" gap. See exploded views assembly manual drawing 00572 & 00572-H13.

Oil, fuel & battery disposal:

All oil, fuel and batteries must be recycled or disposed of in accordance with federal and local laws. Automotive part stores or service centers may collect oil, fuel and batteries or direct you to a facility that can. **Earth911.com** is also a good source for finding a local recycling center.

HYDRAULIC SYSTEM

Hydraulic oil / fluid:

There is no set replacement interval for hydraulic oil. Hydraulic oil life can vary greatly depending on operating conditions.

- Hydraulic oil capacity approximately 8.13 U.S. gallons (30.78 liters).
- Check reservoir level using sight gauge on side of reservoir. Check before operating and immediately after cycling all hydraulic components.
- Add hydraulic oil to the reservoir if oil level is below the sight gauge. In ambient temperatures above 32°F (0°C) use AW or ISO 68 hydraulic fluid. If consistently used below 32°F (0°C) use AW or ISO 46 hydraulic fluid.
- Change hydraulic fluid filter after the first 50 hours of use. Change it every 200 hours thereafter.
- Add approximately 1qt (1 liter) of hydraulic fluid to reservoir with each filter change.
- Recycle / discard the old filter according to environmental standards in your geographic area.
- Check all hydraulic fittings for leaks and tighten if necessary.

NOTICE:

- Running the trencher without hydraulic fluid will cause serious damage to the hydraulic pump. Ensure that the reservoir fluid level is to the top of the sight glass before starting the machine
- Use BARRETO hydraulic oil filters. Automotive oil filters may fit but are not designed for use in high pressure oil systems, the filter element may come apart and contaminate the hydraulic oil.

HOUR METER

The **DGI® TACH/HOUR** meter tracks the hours of machine operation in order for routine maintenance to be performed on a timely basis.

Your **DGI®** hour meter is pre-set at the **DGI®** factory to go into **Flash Alert** mode at 25-hour intervals. Although the engine manufacturer does not require changing engine oil this often, **due to heavy-duty use and extreme conditions inherent to STK use, Barreto Manufacturing strongly recommends frequent engine oil changes.**

Refer to this manual for equipment service requirements and to the **Engine Manual** for other engine service requirements.

While **Flash Alert** is active, hold the tip of the RESET TOOL (Key Kancel Wand) against the meter as shown. Within several seconds the display will stop flashing indicating the Service Interval has been reset. If the wand gets lost, a small mechanic's pick-up magnet will reset the meter.

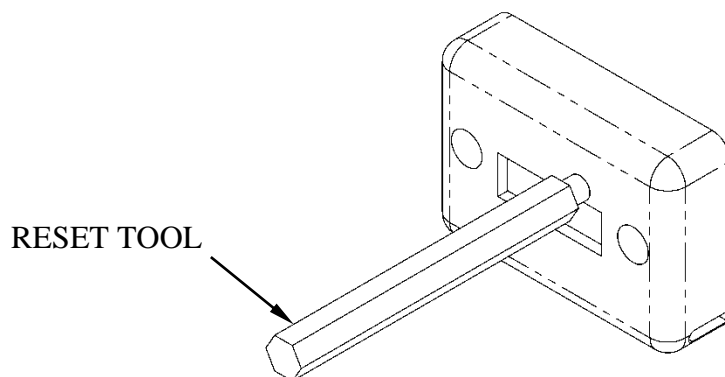

ENGINE MAINTENANCE

Follow the instructions in your engine operator's manual for all engine maintenance.

Barreto Manufacturing has added an engine oil drain hose to your engine to facilitate easier oil changes. Due to heavy duty use inherent to trenching, Barreto Manufacturing recommends that you change your engine oil every 25 hours. Check your engine oil level daily prior to use, and after every 8 hours of use.

Engine oil recommendation is temperature based, see your engine owner's manual for more information. Both engines recommend using their respective branded engine oil.

Vanguard: synthetic 5W-30

Honda: 10W-30 below 85°F (30°C), 10W-40 above 85°F (30°C)

LUBRICATION REQUIREMENTS

Grease:

Grease at the intervals indicated in the following illustration of grease points. Wipe away excess grease.

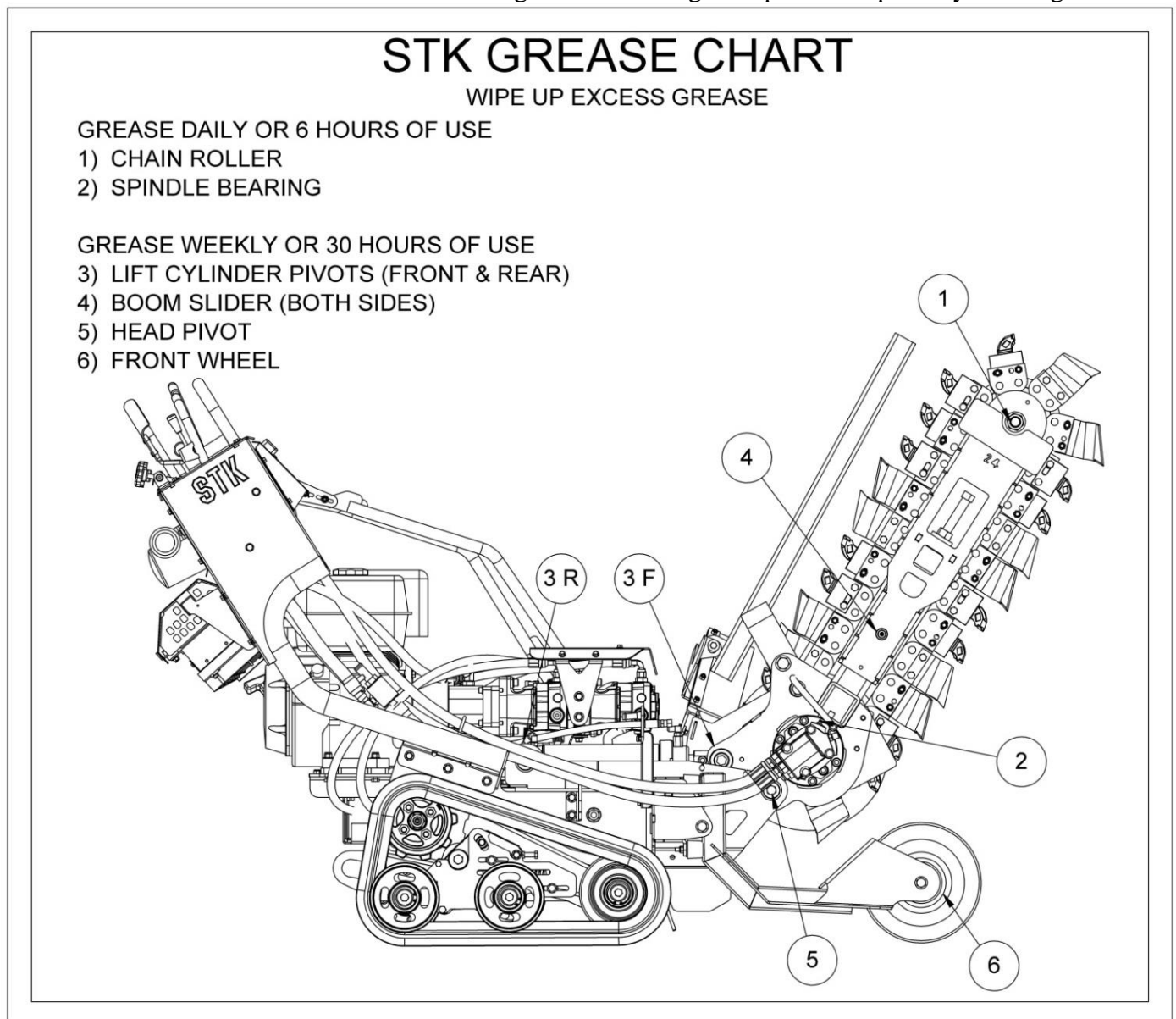

DIG CHAIN INSTALLATION / REPLACEMENT

 **DANGER:** Before beginning any work on the dig chain engine start-up must be prevented. See the MAINTENANCE PREPARATION section page 6.

 **WARNING:** Never place any part of your body underneath the boom, the boom can creep down or lower. The boom can be rested on a stand to prevent creep during maintenance.

Inspect the dig chain for proper chain tension and broken or worn teeth.

Chain tension:

Position the boom so that it is horizontal, parallel with the ground. At the booms mid-section there should be a 2" (5cm) gap between the chain and the bottom of the boom.

If the chain is not properly tensioned, turn the square head bolt in the middle of the boom clockwise to increase the tension or counterclockwise to reduce the chain tension.

- Chains with bolt on teeth: Worn or damaged teeth can be replaced, as a set or individually.
- Chains with weld on teeth: The teeth and chain must be replaced as a unit.

To remove the dig chain:

1. Lower the boom until it is approximately parallel to the ground but not touching the ground.
2. Turn engine off: Follow **Prevent engine start-up** procedure.
3. Locate and remove the cotter pin and chain pin.
4. Unwrap the chain from the sprocket and boom roller to remove.

To install the dig chain:

1. Lower the boom until it is approximately parallel to the ground but not touching the ground.
2. Turn engine off: Follow **Prevent engine start-up** procedure.
3. Loosen the square head bolt in the middle of the chain boom and slide the boom all the way back.
4. Place an end of the chain on top of the boom such that the teeth are up and facing forward.
5. Manipulate the chain over the sprocket until both ends of the chain meet on top of the boom.
6. Install the chain pin to join both ends of the chain, install a cotter pin through the chain pin and bend both ends of the cotter pin around the chain pin. Never reuse a cotter pin on the dig chain.
7. Check and properly adjust the chain tension. See above, in this section.

SEE DIAGRAM INSTALLED DIG CHAIN ON PAGE 12

TRACK MAINTENANCE

 **DANGER:** Before beginning any work on the track system engine start-up must be prevented. See the MAINTENANCE PREPARATION section page 6.

NOTICE:

- Tracks must be correctly tensioned. Loose tracks may de-track, tight tracks will cause excessive wear. Each track must be checked and adjusted individually.
- DO NOT attempt to remove the spring retaining bolt (3/4" head) with the track carriage fully assembled. It is not necessary for track replacement and will result in extra work.

Refer to drawings 00570-R or -L in your exploded views manual and the diagram **TRACK TENSION ADJUSTMENT** on the next page.

Check track tension:

With the STK on flat ground, measure the length of the spring, the spring should be 5in (12.7cm). The spring is visible through slots in the side plates of the under-carriage frame. The track will stretch as it wears. Check spring length with every engine oil change.

Adjust track tension:

With the STK on flat ground:

- Loosen, but do not remove the two tensioner retaining bolts and jam nut on tension adjusting bolt.
- Turn the tension adjusting bolt until the spring is 5in: clockwise to decrease spring length, increases track tension; counterclockwise to increase spring length, decreases track tension.
- Tighten the two tensioner retaining bolts and the jam nut.
- Drive the STK a few feet and re-check track tension, re-adjust if necessary.

Remove / Install track:

- Lift the STK until the track is completely off the ground.
- Loosen, but do not remove the two tensioner retaining bolts and jam nut on tension adjusting bolt.
- Remove both outer idler wheels.
- Loosen the tension adjusting bolt until the track is loose enough to be easily removed.
 - Use a soft mallet or wood blocks to drive idler rollers forward until the tensioner retaining bolts are at the front of the slots.
- Install the new track; the new track will be tighter than the used track.
- Replace both outer idler wheels.
- Tighten the tension adjusting screw until the spring is 5in.
- Tighten the two tensioner retaining bolts and the jam nut.
- Lower the STK back onto flat ground.
- Drive the STK a few feet and re-check track tension, re-adjust if necessary.

See diagram TRACK TENSION ADJUSTMENT on the next page.

INSTALLED DIG CHAIN

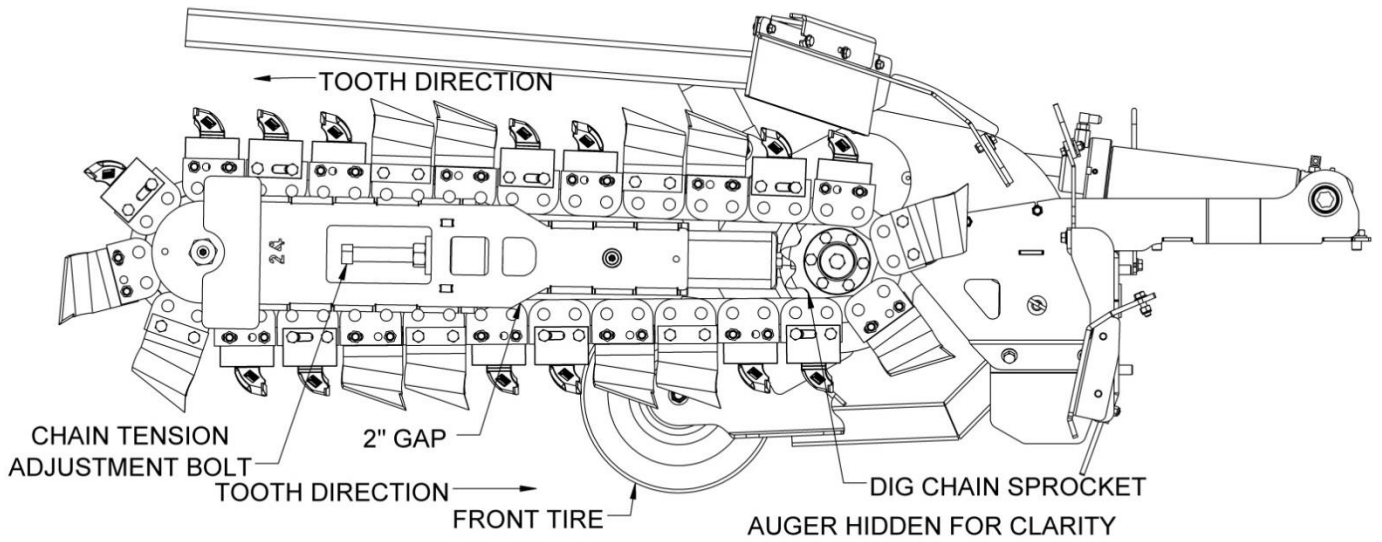

TRACK TENSION ADJUSTMENT

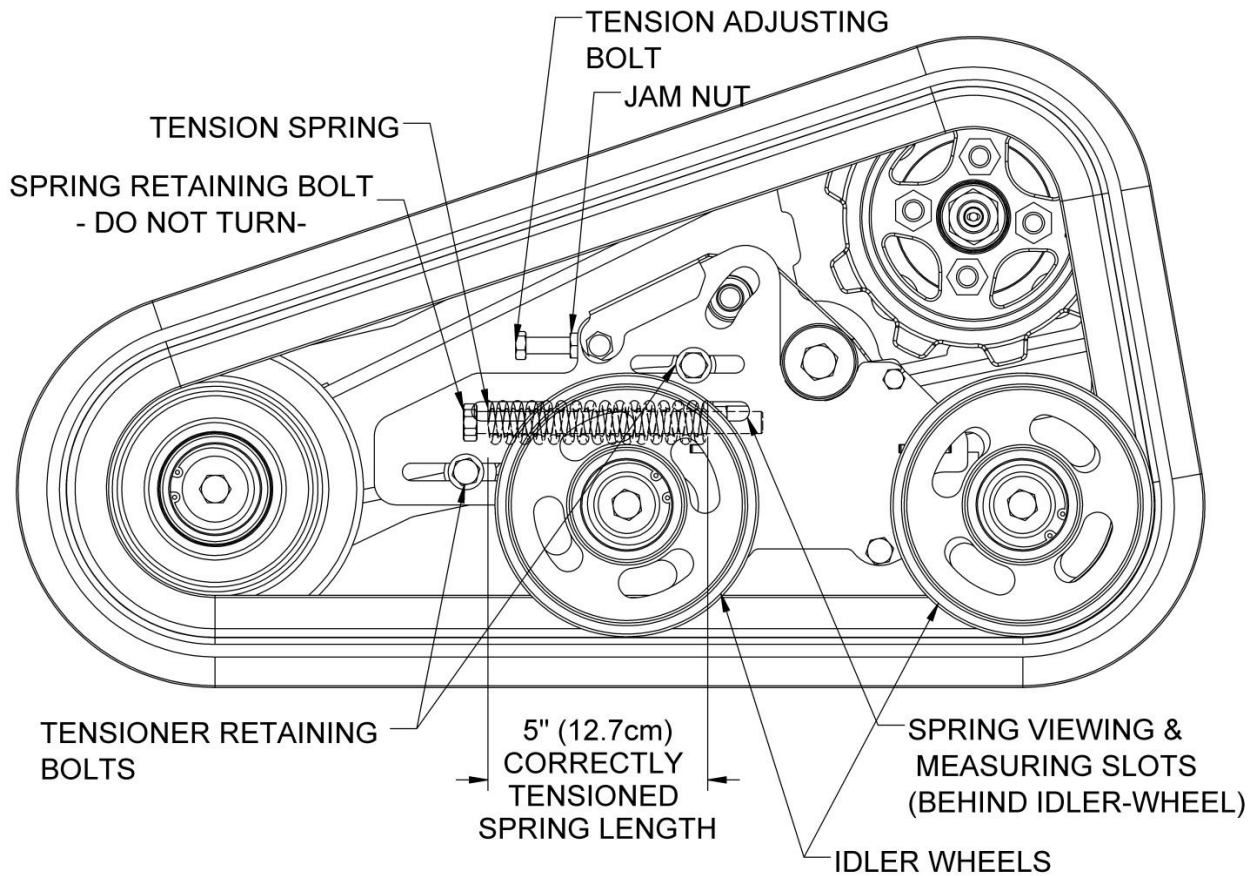

BATTERY SAFETY INSTRUCTIONS

Only trained and qualified personnel should perform maintenance or repairs of the STK or the battery.



WARNING: The battery contains sulfuric acid that can cause blindness and severe burns. Avoid contact with eyes, skin and clothing.



WARNING: Battery fumes are flammable and explosive. Avoid exposing the battery to sparks and flames. Sparks can be created near the battery when handling battery cables or jumper cables.



WARNING: The battery, posts, terminals, and related accessories contain lead and lead compounds, chemicals known to the State of California to cause cancer and reproductive harm.



WARNING: Wear appropriate personal protective equipment when handling the battery. Shield entire face, especially your eyes, wear rubber gloves and a rubber apron to reduce the risk of acid burns. Battery caps must be tightly in place if the battery has removable caps.

First Aid Measures from Material Safety Data Sheet, for sulfuric acid: ScienceLab.com

- **Eye Contact:** Check for and remove contact lenses. Immediately flush eyes with plenty of water for at least 15 minutes. Cold water may be used. Get medical attention immediately.
- **Skin Contact:** Immediately flush skin with plenty of water for 15 minutes while removing contaminated clothing and shoes. Cover irritated skin with an emollient. Cold water may be used. Wash clothing before reuse. Thoroughly clean shoes before reuse. Get medical attention immediately.
- **Serious Skin Contact:** Wash with a disinfectant soap and cover the contaminated skin with an anti-bacterial cream. Seek immediate medical attention.
- **Inhalation:** If inhaled, remove to fresh air. If not breathing, give artificial respiration. If breathing is difficult, give oxygen. Get medical attention immediately.
- **Serious Inhalation:** Evacuate the victim to a safe area as soon as possible. Loosen tight clothing such as a collar, tie, belt, or waistband. If breathing is difficult, administer oxygen. If the victim is not breathing, perform mouth-to-mouth resuscitation. Seek immediate medical attention



WARNING: It may be hazardous to the person providing aid to give mouth-to-mouth resuscitation when the inhaled material is toxic, infectious or corrosive.

- **Ingestion:** DO NOT induce vomiting unless directed to do so by medical personnel. Never give anything by mouth to an unconscious person. Loosen tight clothing such as a collar, tie, belt or waistband. Get medical attention if symptoms appear
- **Serious ingestion:** Not available

Emergency & Medical Contacts:

USA & CANADA: Emergency dial **911**

USA & CANADA: American Association of Poison Control Centers: **1-800-222-1222**

Outside the USA & Canada (Please fill in the appropriate number)

National Emergency number: _____

Poison Control Center: _____

Other: _____

BATTERY MAINTENANCE



WARNING: Read the section: **BATTERY SAFETY INSTRUCTIONS**, before handling the battery.

The original battery equipped on the STK is considered to be “maintenance free”. However, some maintenance will help your battery last longer. Temperatures below freezing or over 90°F (32°C) will reduce the life of the battery. If the battery is not going to be used for a season, store it fully charged in an area where the temperature will stay between freezing and 90°F (32°C). This will help prolong battery life.

NOTICE: Battery acid is corrosive and can damage your machine. Keep the battery clean and avoid getting battery acid on your machine.

Always recycle / dispose of your old batteries properly. Most places that sell automotive batteries will take your old battery. **DO NOT** dump your battery. **DO NOT** put your battery in a dumpster.

Always replace any damaged battery or battery components, such as wires, clamps, lugs, fasteners, isolators, covers, etc.

To remove your battery: Engine must be off. All engine switches must be in the OFF position.

- Disconnect the ground cable at the chassis and position it to not touch any component.
- Disconnect the ground cable at the battery and set it aside.
- Disconnect the positive cable from the battery; the cable may remain connected to starter motor.
- Remove the battery from holder. Place on a clean, dry, level, non-conductive surface. Keep away from flames, sparks and heat sources.
- **DO NOT** store where the ambient temperature is less than freezing or hotter than 90°F (32° C).

To install your battery: Engine must be off. All engine switches must be in the OFF position.

- Place battery in battery compartment.
- Connect the positive cable to the battery and the starter motor.
- Make sure that the ground cable is not touching any machine component.
- Connect the ground cable to the battery.
- Install the battery isolator and cover.
- Connect the ground cable to the chassis.

To clean your battery: information from www.interstatebatteries.com

- Disconnect your battery. See: **To remove your battery:** the battery may remain in the holder.
- Make sure vents caps are pressed securely into battery.
- Clean terminals and lugs with a mixture of baking soda and water. A wire brush may be used.
- Clean STK components near the battery with baking soda and water. **DO NOT** use a wire brush.
- Rinse with clean water and allow enough time for water to dry.
- Coat terminals and wire lugs with dielectric grease.
- Connect your battery. See: **To install your battery:**

To check the electrolyte level and add water: Information from www.interstatebatteries.com

The battery supplied with the STK is sealed. Electrolyte level cannot be checked, water cannot be added.

If using a non-sealed battery: Information from www.interstatebatteries.com

It is particularly important to check electrolyte levels during hot weather.

- Pry removable vent caps off with a flat head screwdriver. You will see individual vent wells.
- Carefully look into each individual cell to make sure that the water is covering the lead plates.
- Add **distilled water** to any cells that are low on water. **DO NOT OVER FILL**, add water slowly, add just enough water to cover the lead plates or to a fill line indicator if equipped.
- Re-install removable vent caps: make sure that they are fitted all the way in place.



DANGER: Keep your eye away from the battery while looking into a battery cell. Stay a safe distance back and use a flashlight.



WARNING: Wear appropriate personal protective equipment when handling the battery. Shield entire face, especially your eyes, wear rubber gloves and a rubber apron to reduce the risk of acid burns. Battery caps must be tightly in place if the battery has removable caps.

NOTICE: Only use distilled water, available at most grocery stores. Tap water and other drinking water have impurities that will damage your battery.

To recharge the battery:

Read, understand and follow all safety and operating instructions from your battery charger. Make sure that your battery charger is rated appropriately to charge the battery. If voltage and amperage can be adjusted on your charger, make sure they are adjusted correctly to your battery. **DO NOT** over charge your battery.

STK TROUBLE SHOOTING GUIDE



DANGER: Before doing any trouble shooting that exposes a moving part or requires someone to be near the boom or track system, engine start-up must be prevented. See the MAINTENANCE PREPARATION section page 6.

Drawings referred to in this section can be found in your assembly exploded views manual.

A. Entire hydraulic system does not operate, and the engine is not under load.

1. Low hydraulic fluid in tank.
Add hydraulic fluid until it shows in sight gauge.
2. Hydraulic pump-to-engine coupler has slipped.
Check couplers and rubber spider, replace as needed. See drawing 00572, 00572-H13
NOTICE: Engine – pump couplers must have a 1/8” gap.
3. Main pump suction leaking air into pump intake.
Check main suction hoses and fittings for leaks and tighten fitting nuts.

B. Engine lugs down or dies, tracks and chain do not turn.

1. Rocks or other obstructions stopping chain.
Reverse chain momentarily to free it from obstruction. Remove obstruction from trench.
2. Trenching depth or speed too great for soil conditions.
Decrease ground speed or trenching depth.
3. Engine improperly tuned or maintained.
See engine manual and correct as needed.
4. Low oil alert causes engine to shut down.
This may occur when trenching on hills. Level trencher allow oil alert to reset. Check oil level, fill as needed.
5. Engine losing power due to wear.
See engine manual, repair or replace as needed.

C. Chain fails to rotate, but track drive works.

1. Chain Control Relief Valve out of adjustment.
Adjust Relief Valve to 2800 PSI (E13STKH) / 3300PSI (16STKB), replace relief spring if needed. See drawing 00322-STK, contact tech support.
2. Chain motor worn.
Rebuild or replace motor.
3. Chain drive pump worn.
Replace pump. New hydraulic motors and pumps are available from Barreto Manufacturing.
4. Spindle splines stripped out.
See drawing 00574

D. Tracks fail to turn, but chain rotates.

1. Sprocket key sheared.
Replace key. See drawings 00584 & 00585.
2. Check control arm connections to control levers and track drive pumps.
Ensure all fasteners are in place and tightened.
3. Check, by hand, that track drive pump bypass valves are tight.
If loose, tighten to 100 In-lb. (11.3 N-m). **DO NOT REMOVE NUT.** See Operators Manual RECOVERY TOWING section.

E. Hydraulic fluid leaks in hydraulic system.

1. Fittings are loose.
Tighten fittings on hoses and adapters.
2. Worn or broken hoses.
Replace damaged hoses.
3. Hydraulic fluid around chain motor or shaft.
Inspect motor for leaking shaft seal. Rebuild or replace motor. New motors are available from Barreto Manufacturing.



DANGER: Hydraulic oil is hot and under extreme pressure, which will burn and cut.

DO NOT operate machine if it is believed or known to be leaking.

DO NOT check for hydraulic oil leaks while engine is running.

DO NOT check for hydraulic oil leaks with your hand or any other body part.

If cut or injected with hydraulic oil, seek medical attention immediately, even if injury appears to be minor. If hydraulic oil does not break skin, contact is not expected to cause prolonged or significant irritation.

F. Foaming hydraulic fluid coming from breather hose.

1. Improper fluid used.
Verify that hydraulic fluid used had antifoaming additives. Tractor transmission / hydraulic fluid AW or ISO 68 is recommended for use in temperatures above +32°F.
2. Air leaking into fluid.
Inspect and tighten fittings and clamps on pump intake hoses.

G. Boom does not lift or does not lower into ground.

1. Boom lift relief valve malfunctioning.
Adjust relief to 1000 PSI, may require a replacement valve spring. See drawing 00582 & contact tech support.
2. Boom cylinder piston seal damaged or rod bent.
Disassemble & replace parts as required.
3. Boom pivot bushing seized.
Disassemble, inspect, clean & replace parts as required.

SPECIFICATIONS

MODEL NUMBERS: E16STKB; E13STKH

DIMENSIONS (APPROXIMATE, STORAGE POSITION)

GVWR: 1080lbs. (490kg)
Width: 33-1/2" (0.85m) (E13STKH)
Width: 35" (0.89m) (E16STKB)
Length: 81" (2.06m) (24" BOOM)

ENGINE E16STKB

Engine: Vanguard™ 16.0 Gross Hp
Power: 16hp (11.9 kW) at 3600 RPM
Fuel: Gasoline
Fuel Capacity: 5 U.S. Gallons (18.9 liters) External tank
Oil Capacity: 1.5 U.S. Quarts (1.4 liters)
Start: Pull & Electric

Engine E13STKH

Engine: Honda GX390
Power: 11.7hp (8.7kW) @ 3600 RPM
Fuel: Gasoline
Fuel Capacity: 1.6 U.S. Gallons (6.1 liters)
Oil Capacity: 1.16 U.S. Quarts (1.1 liters)
Start: Pull & Electric

INDEX

ASSEMBLY INSTRUCTIONS, 3
BATTERY MAINTENANCE, 14, 15
DECALS, 5, 7
HOUR METER, 8
HYDRAULIC FLUID, 8, 16, 17
HYDRAULIC OIL FILTER, 8
INTENDED USE, 4
LUBRICATION, GREASE, 7, 9, 14
LUBRICATION, OIL, 6, 8, 9
MAINTENANCE, 2, 6, 7, 8, 9, 13, 14
OPERATOR TRAINING, 5
SPECIFICATIONS, 18
WARRANTY, 2